

User manual

BA SERIES - TORQUE REACTION ARMS
LINEARS, ARTICULATED, CARTESIANS
WITH / WITHOUT POSITION CONTROL

Series : BA / BA...PCL / BA...TWIN / BA...R /
BA...RPC / BA...G / BA...GPC / BA...C



EN

60351-07/24

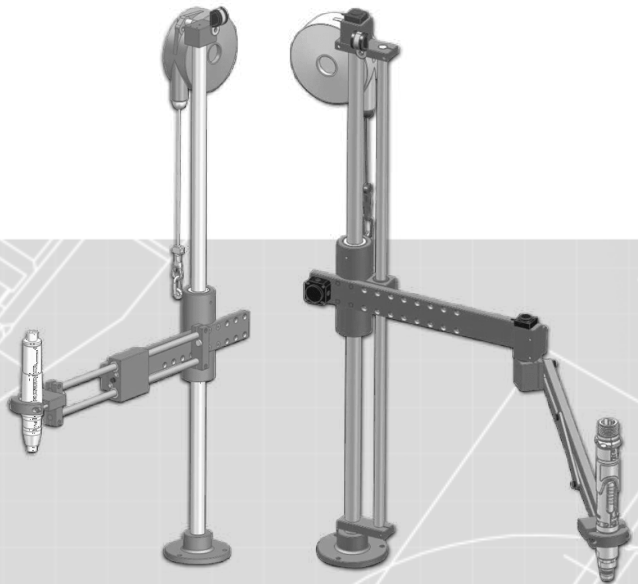

CONTENTS

REMARKS ABOUT THE MANUAL	4
Symbols	4
Acronyms	4
1. INFORMATION	5
1.1 IMPORTANT	5
1.2 Product reference	5
1.3 General equipment description	6
1.4 Standard equipment presentation	7
1.4.1 Linear torque reaction arm.....	7
1.4.2 Articulated torque reaction arms	11
1.4.3 Cartesian torque reaction arm	17
1.5 Packing List	18
1.6 Technical specifications	19
1.6.1 Linear torque reaction arm's specifications.....	19
1.6.2 Articulated torque reaction arm's specifications	22
1.6.3 Pneumatic articulated torque reaction arm's specifications	25
1.6.4 Cartesian torque reaction arm specifications.....	27
2. STARTING UP	29
2.1 Workstation description	29
2.2 Unpacking	29
2.3 Configuration	29
2.4 Installation	30
2.4.1 Main shaft foot installation	30
2.4.2 Shift adjustment B min. / B max.....	31
2.4.3 Tool installation	31
2.4.4 Balancer installation	32
2.4.5 Encoder check (Series : BA...PCL, BA...RPC, BA...GPC).....	32
2.4.6 Mounting instructions BA...PCL	33

2.4.7 Air pressure check (serie BA...G, BA...GPC).....	34
3. SETTINGS	35
3.1 Balancer setting	35
3.2 Inclination setting (BA...R series)	35
4. USE.....	36
4.1 Standard use	36
4.2 Positioning control use	36
5. MAINTENANCE	37
5.1 Servicing	37
5.2 Troubleshooting	38
5.3 Spare parts	39
5.4 Phone support.....	39
5.5 After-sales returns	40
5.5.1 Download the after-sales return form	40
5.5.2 Send your equipment	41
5.6 On-site repair.....	41
5.7 Warranty.....	42
6. SAFETY	43
6.1 General provisions	43
6.2 Residual risks.....	44
6.2.1 Pinching or cutting risks.....	44
6.2.2. Injury risk	44
6.3 Contra-indications	44
7. STANDARDS	45
7.1 Manufacturer details	45
7.2 Markings	45
7.3 Transport and storage.....	46
7.3.1 Transport	46
7.3.2 Storage.....	46
7.4 Recycling and end of service life	46
8. ANNEXES	47
8.1 EC declaration of conformity.....	47

REMARKS ABOUT THE MANUAL

Symbols



Information

This warning statement indicates important information (for example: damage to property), but no hazard.



Information

Information to view in your customer area on the www.doga.fr web site.



Caution

This warning statement indicates a low risk that may lead to minor or moderate injuries if not avoided.



Wear personal protection equipment

This symbol indicates the need to wear protective gloves.



Warning

This warning statement indicates a moderate risk that may lead to severe or fatal injuries if not avoided.

Acronyms

BA : Assistance arm

PC : Positioning control

R : Double articulation

G : Pneumatic balancing

TWIN : Double tools

1. INFORMATION

1.1 IMPORTANT

The tool supplied with this manual may have been altered to meet specific needs.

If this is the case, when ordering a replacement or spare parts, please indicate the tool item code featured on the delivery document, or contact **DOGA** at **+33 1 30 66 41 41** indicating the approximate delivery date. You will then be sure to get the required tool and/or parts.

1.2 Product reference

Description	Torque arms
Type	BA BA...PCL BA...TWIN BA...R BA...RPC BA...G BA...GPC BA...C

1.3 General equipment description

DOGA's BA torque reaction arms are available in several geometries (linear, articulated, cartesian).

They are designed to be easily installed on your worktops or on the floor and are ideal for screwing operations.

They are used for distinct and complementary functions:

- a) Cancel the torque reaction effect of hand-tools with rotary motor such as screwdrivers, drills or tappers. They guarantee the dampening of shocks and vibrations delivered by these tools, thus preventing musculoskeletal disorders.
- b) Ensure the suspension and balancing of the tools.
- c) Guarantee perfect perpendicularity between the tool and the work surface.
- d) With encoders mounted to the arms (PC version), they can be used for position control.

1.4 Standard equipment presentation

1.4.1 Linear torque reaction arm

1.4.1.1 BA series (5 to 100) and BA TWIN

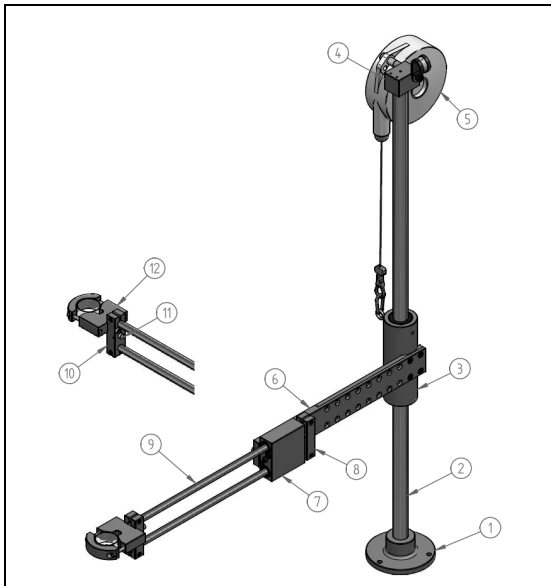

1	Main shaft foot
2	Main shaft
3	Sliding bushing
4	Balancer support
5	Balancer
6	Primary arm plate
7	Thrust ball bearing
8	Back flange
9	Set of 2 slides
10	Front flange
11	Magnet
12	Clamp

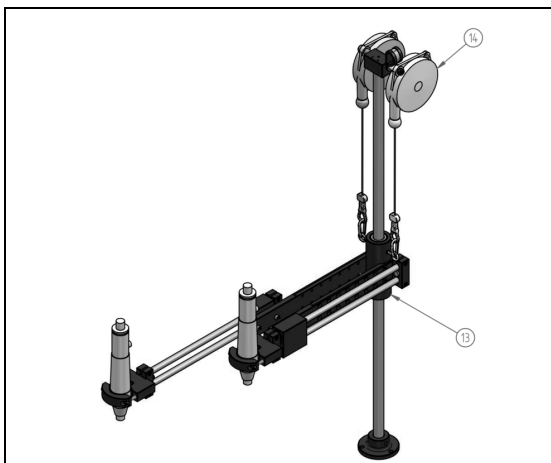

13	Twin needle bushing <i>(Replace rep. 3)</i>
14	Twin balancer (x 2)

Rep.	BA 5	BA 12 BA 12 T	BA 25 BA 25 T	BA 40 BA 40 T	BA 100 BA 100 T
1	4-5200990	4-5200150	4-5200170	4-5200183	4-5200196
2	4-5200991	4-5200151	4-5200171	4-5200184	4-5200197
3	4-5200992	4-5200152	4-5200172	4-5200185	4-5200198
4	4-5200993	4-5200153	4-5200173	4-5200186	4-5200199
5	4-1200005	4-1200006	4-1200006 and 4-1200005	4-1200008	4-1200050
6	4-5200994	4-5200155	4-5200175	4-5200189	4-5200205
7	4-5200156	4-5200156	45200176	4-5200190	4-5200206
8	4-5200157	4-5200157	4-5200177	4-5200191	4-5200207
9	4-5200995	4-5200158	4-5200178	4-5200192	4-5200208
10	4-5200159	4-5200159	4-5200180	4-5200193	4-5200209
11	4-5200168	4-5200168	4-5200181	4-5200194	4-5200223
12	4-5200018	4-5200169	4-5200182	4-5200195	4-5200224
13	-	<i>(on request)</i>			
14	-	<i>(on request)</i>	4-1200004 and 4-1200005	4-1200008 and 4-1200007	2 x 4-1200050

1.4.1.2 BA...PCL series

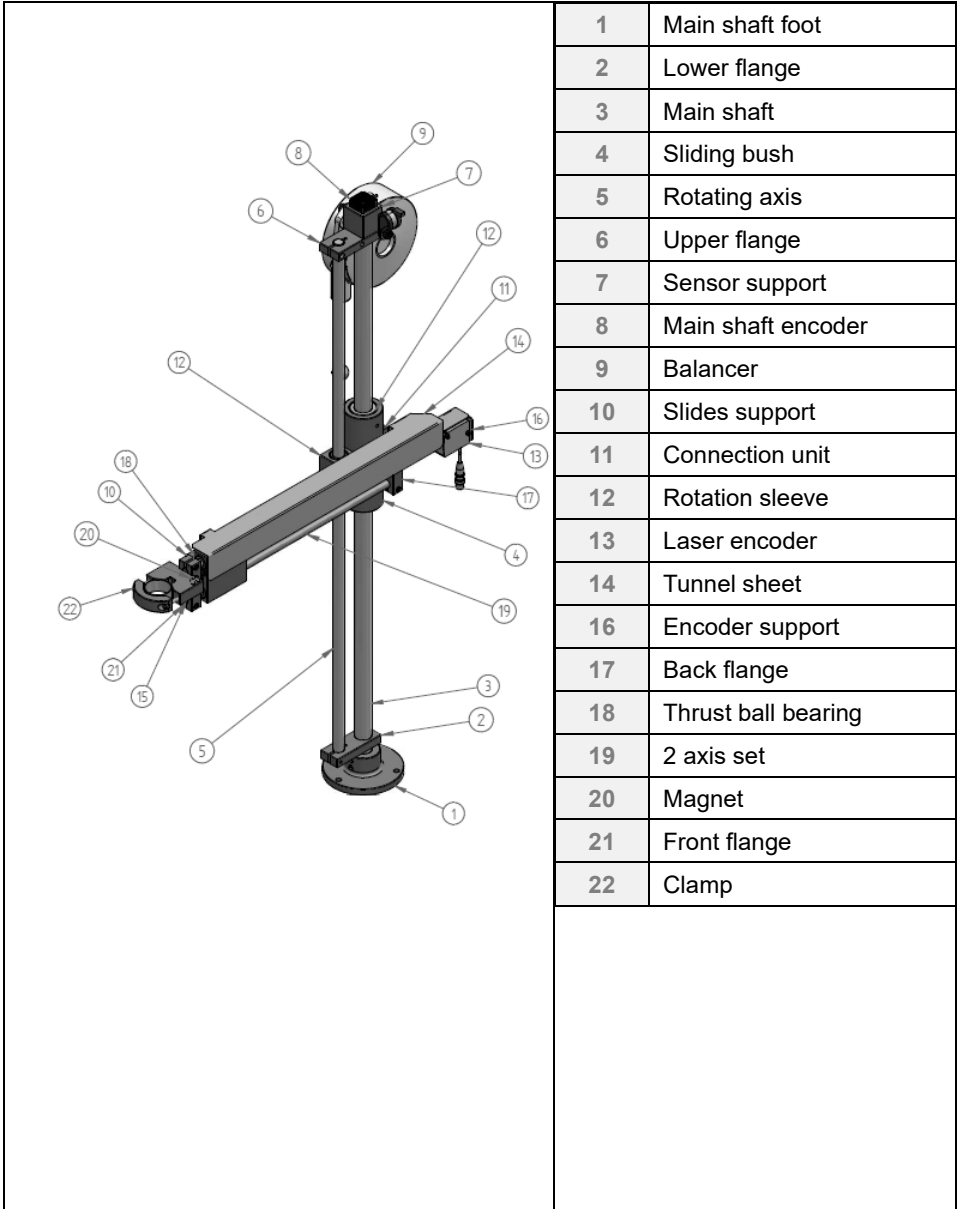

1	Main shaft foot
2	Lower flange
3	Main shaft
4	Sliding bush
5	Rotating axis
6	Upper flange
7	Sensor support
8	Main shaft encoder
9	Balancer
10	Slides support
11	Connection unit
12	Rotation sleeve
13	Laser encoder
14	Tunnel sheet
16	Encoder support
17	Back flange
18	Thrust ball bearing
19	2 axis set
20	Magnet
21	Front flange
22	Clamp

Rep	BA12PCL	BA25PCL	BA40PCL	BA40PCL/400	BA100PCL	BA100PCL/400
4	P112328	P103129	P105490		P108392	
8	P100074	P100074	P100074		P100074	
9	P100414	P100253	P100246	P100504	P100504 + P100056	P100504 + P100041
11	P100127	P100127	P100127		P100127	
13	P006252	P006252	P006252		P006252	
14	P205143	P012549	P012788	P012552	P204918	P205145
16	P205153	P012548	P012695	P012695	P204919	P204919

Spare parts list on request.

1.4.1.3 BA series (200 to 400)

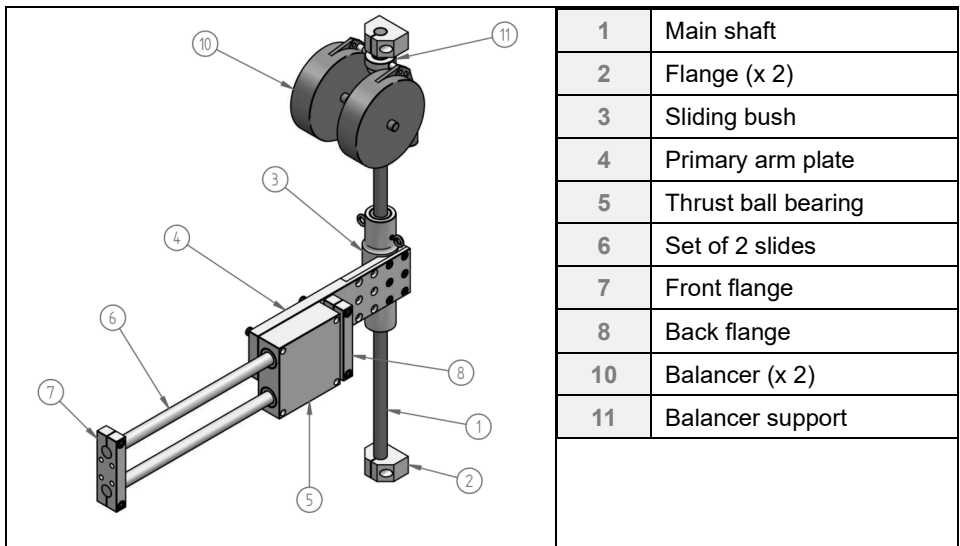

Spare parts list on request.

1.4.2 Articulated torque reaction arms

1.4.2.1 BA...R series

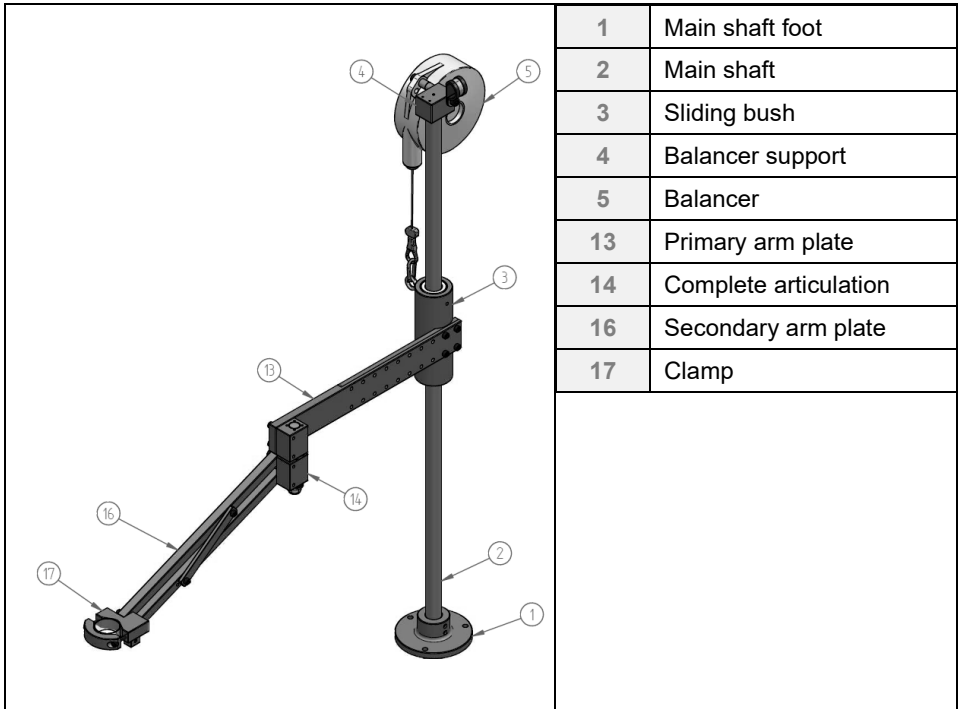

1	Main shaft foot
2	Main shaft
3	Sliding bush
4	Balancer support
5	Balancer
13	Primary arm plate
14	Complete articulation
16	Secondary arm plate
17	Clamp

Rep.	BA 5 R	BA 12 R	BA 12 R /600	BA 25 R	BA 25 R /600	BA 25 R /800
1	4-5200555	4-5200225		4-5200246		
2	4-5200556	4-5200226		4-5200247		
3	4-5200557	4-5200227		4-5200248		
4	4-5200558	4-5200228		4-5200249		
5	4-1200005	4-1200006		4-1200005 et 4-1200006		
13	4-5200626	4-5200238	4-5200458	4-5200251	4-5200496	4-5200545
14	4-5200654	4-5200243		4-5200252		
16	4-5200656	4-5200244	4-5200479	4-5200253	4-5200514	4-5200547
17	4-5200657	4-5200245		4-5200254		

Rep.	BA 40 R	BA 40 R/800	BA 40 R/1000	BA 100 R	BA 100 R/900	BA 100R /1100
1	4-5200255			4-5200264		
2	4-5200256			4-5200265		
3	4-5200257			4-5200266		
4	4-5200258			4-5200267		
5	4-1200008			4-1200050	4-1200008	
13	4-5200260	4-5200609	4-5200639	4-5200269	4-5200692	4-5200709
14	4-5200261			4-5200270		
16	4-5200262	4-5200612	4-5200652	4-5200271	4-5200700	4-5200713
17	4-5200263			4-5200272		

1.4.2.2 BA...RPC series

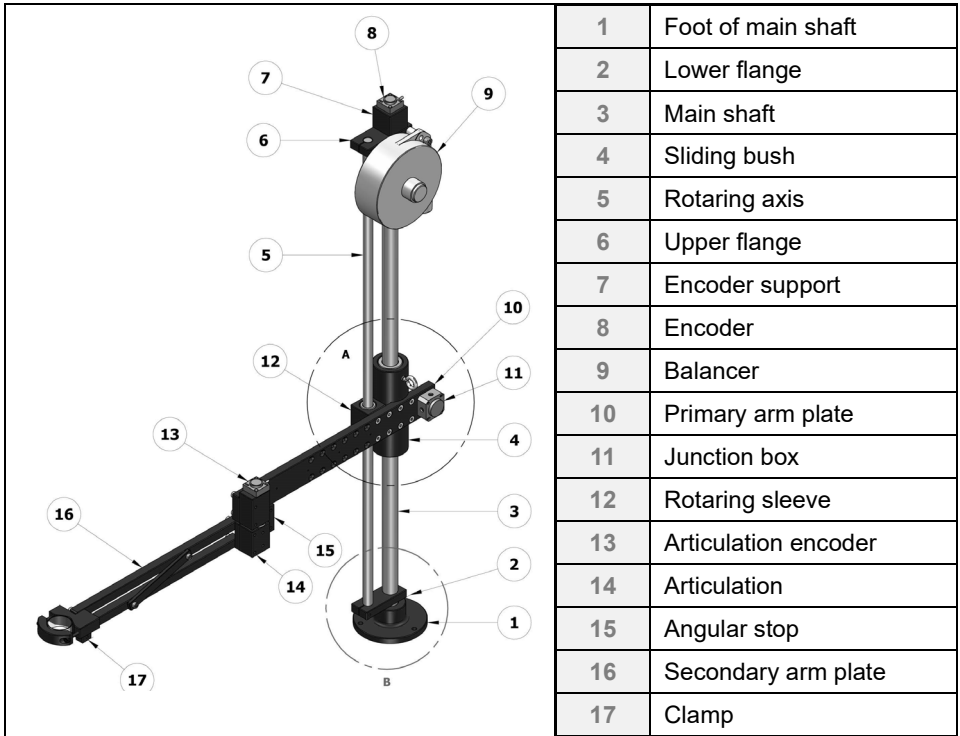

Rep.	BA 12 RPC	BA 25 RPC	BA 25 RPC/600
1	4-5200225	4-5200246	
8	4-5200484	4-5200484	
9	4-1284444	4-1200007	
11	4-5200488	4-5200488	
13	4-5200485	4-5200485	4-5200560
16	4-5200244	4-5200253	4-5200514
17	4-5200245	4-5200254	

Complete spare parts list on request.

Rep.	BA 40 RPC	BA 40 RPC/800	BA 100 RPC	BA 100 RPC/900	BA 100 RPC/1100
1	4-5200255		4-5200264		
8	4-5200484		4-5200484		
9	4-1200008		4-1200050		
11	4-5200488		4-5200488		
13	4-5200486	4-5200561	4-5200487	4-5200562	4-5200563
14	4-5201723	<i>(on request)</i>			
15	4-5201722	<i>(on request)</i>			
16	4-5200262	4-5200112	4-5200271	4-5200700	4-5200713
17	4-5200263		4-5200272		

Complete spare parts list on request.

1.4.2.3 BA...G series

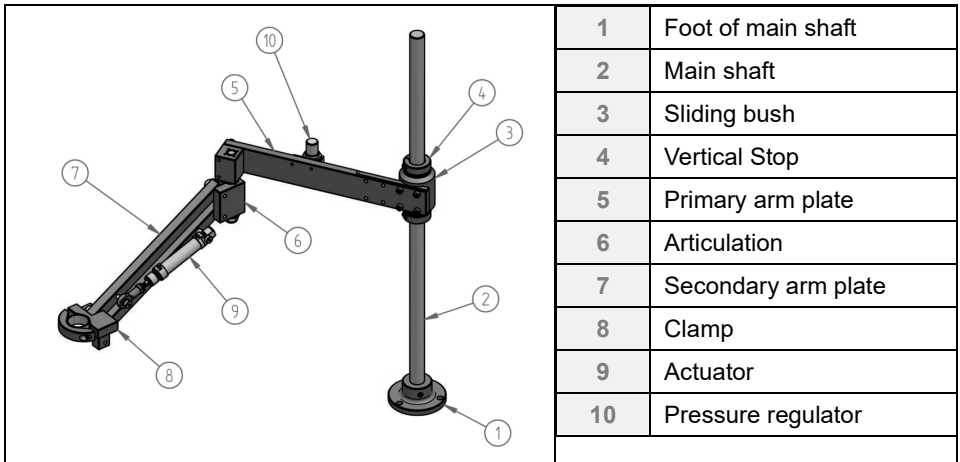

Spare parts list on request.

1.4.2.4 BA...GPC series

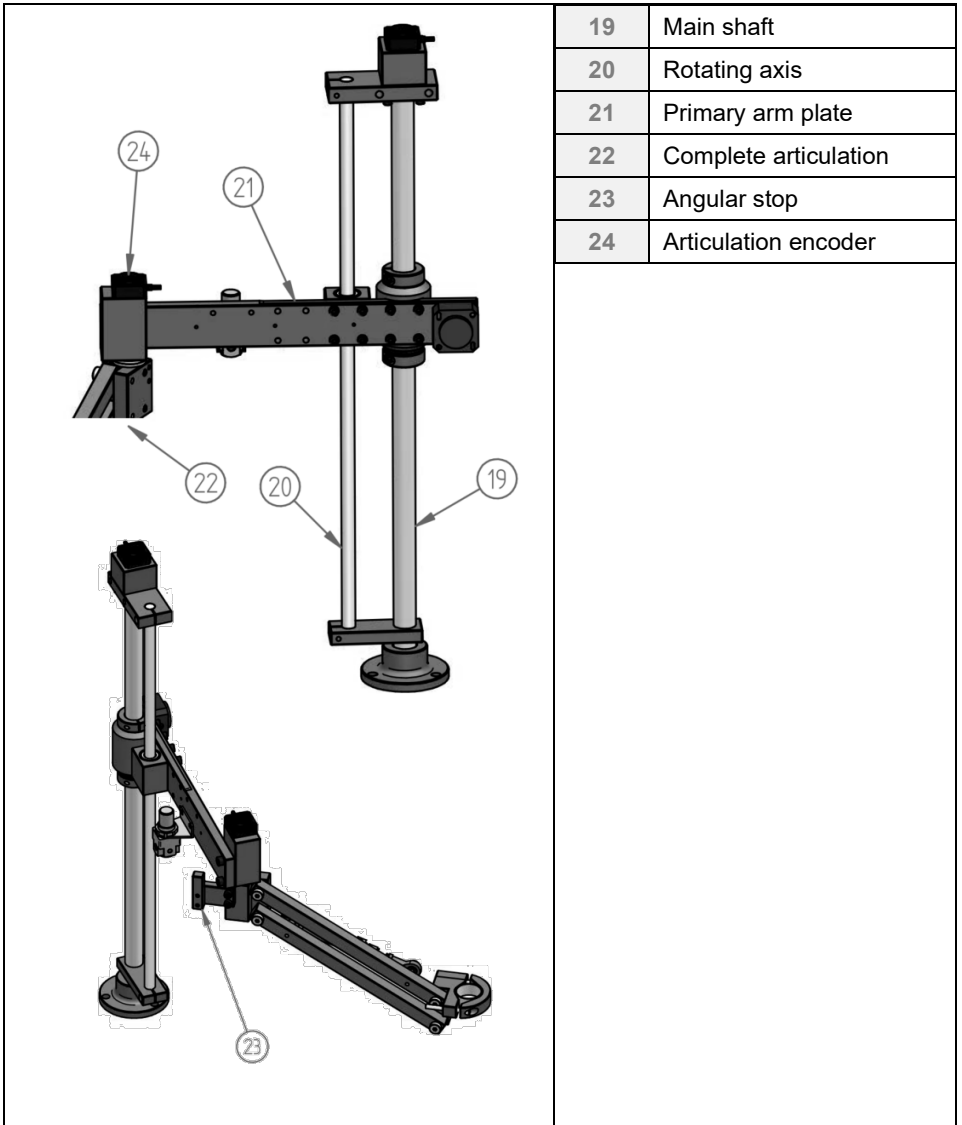

19	Main shaft
20	Rotating axis
21	Primary arm plate
22	Complete articulation
23	Angular stop
24	Articulation encoder

Spare parts list on request.

1.4.3 Cartesian torque reaction arm

1.4.3.1 BA...C series

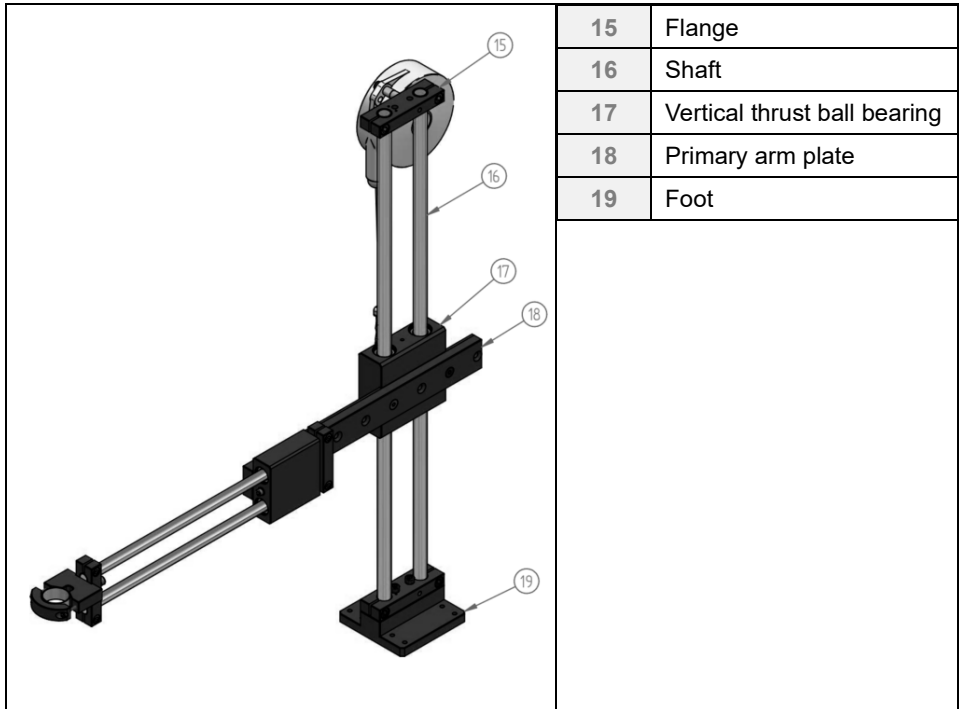

Spare parts list on request.



Information

For all other spare part, please refer to BA series (5 to 100).



Information

For any other design/options, contact us.

1.5 Packing List

x 1 - Torque reaction arms to assemble (2 to 3 subassembly)

All hardware and wiring is pre-installed.

Designation	Packaging dimensions L x W x H		Total Weight	
	(cm)	(in)	(kg)	(lbs)
BA 5	86 x 13 x 13	3,39 x 0,51 x 0,51	3,72	8,18
BA 5 R	96 x 13 x 13	3,78 x 0,51 x 0,51	3,50	7,70
BA 12	85,5 x 13,5 x 13	3,37 x 0,53 x 0,51	5,20	11,44
BA 12 R	85,5 x 13 x 13	3,37 x 0,51 x 0,51	5,48	12,06
BA 12 RPC	107,5 x 23 x 20	4,23 x 0,91 x 0,79	7,52	16,54
BA 25	95,5 x 13 x 13	3,76 x 0,51 x 0,51	6,30	13,86
BA 25 C	106,5 x 18 x 16,5	4,19 x 0,71 x 0,65	7,46	16,41
BA 25 RPC	106,5 x 18 x 17	4,19 x 0,71 x 0,67	8,28	18,22
BA 40 R	106,5 x 18 x 17	4,19 x 0,71 x 0,67	11,10	24,42
BA 40 RPC	106,5 x 18 x 17	4,19 x 0,71 x 0,67	13,50	29,70
BA 100	106,5 x 18 x 17,5	4,19 x 0,71 x 0,69	14,02	30,84
BA 100 R	106 x 18 x 17	4,17 x 0,71 x 0,67	13,30	29,26
BA 100 RPC	106,5 x 20,5 x 30	4,19 x 0,81 x 1,18	16,14	35,51



Information

Other models/options, contact us.

1.6 Technical specifications

1.6.1 Linear torque reaction arm's specifications

1.6.1.1 Technical characteristics

** with additional balancer*

Designation	Max Torque		Tool Ø min-max		Stroke		Max Load			
	(N.m)	(lbf.in)	(mm)	(in)	(mm)	(in)	(kg)	(lbs)		
BA 5	5	44,26	25-42	0,98-1,65	200	7,87	0,9	1,98		
BA 12	12	106,21	25-50	0,98-1,97	200	7,87	1,2	2,64		
BA 12 PCL					195	7,68	1,2	2,64		
BA 12 TWIN					225	8,86	2	4,40		
BA 25	25	221,28	28-52	1,10-2,05	250	9,84	2,2	4,84		
BA 25 PCL					195	7,68	2,2	4,84		
BA 25 TWIN					250	9,84	3	6,60		
BA 40	40	354,04			295	11,61	2,2/4*	4,84/8,80*		
BA 40 PCL/300					295	11,61	2,2	4,84		
BA 40 PCL/400					395	15,55	2,2	4,84		
BA 40 TWIN					295	11,61	4	8,80		
BA 100	100	885,10			330	12,99	3/5*	6,60/11,02*		
BA 100 PCL/300					295	11,61	4	8,80		
BA 100 PCL/400					395	15,55	4	8,80		
BA 200	200	1770,20			-	-	350	13,78	8	17,60
BA 400	400	3540,40			-	-	400	15,75	12	26,40



Warning

Make sure to never use the tools beyond the torque values for which they are designed.



Warning

Never use the tools with effective loads at the end of the arm exceeding the manufacturer's recommendations.

1.6.1.2 Dimensions BA 5 to BA 100

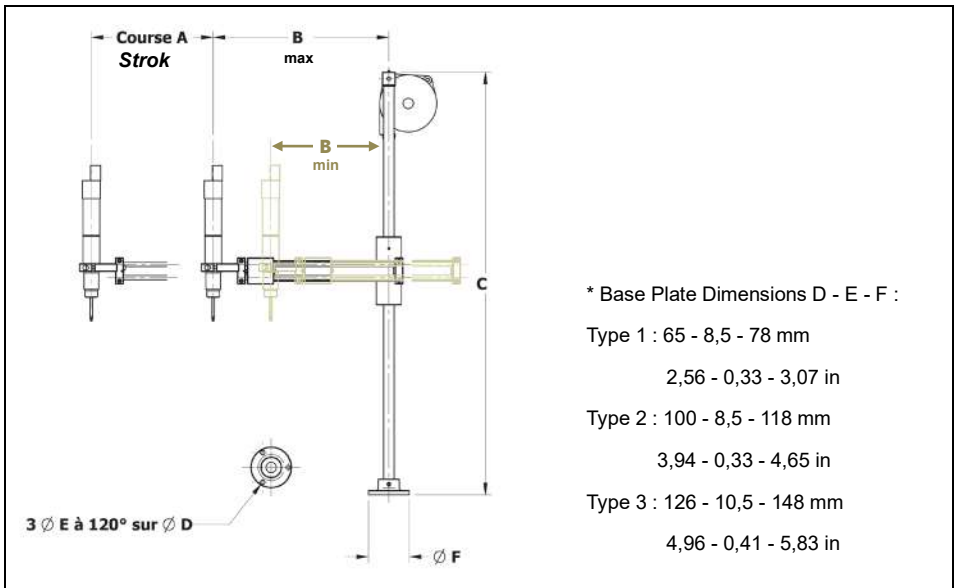

Designation	B min		B max		C		Base Plate*
	(mm)	(in)	(mm)	(in)	(mm)	(in)	
BA 5	235	9,25	315	12,40	705	27,76	Type 1
BA 12	186	7,32	336	13,23	805	31,69	Type 1
BA 12 PCL	236	9,29	336	13,23	816	32,13	Type 1
BA 25	221	8,70	396	15,59	908	35,75	Type 1
BA 25 PCL	251	9,88	351	13,82	916	36,06	Type 1
BA 40	260	10,24	460	18,11	1008	39,69	Type 2
BA 40 PCL/300	320	12,60	470	18,50	1016	40,00	Type 2
BA 40 PCL/400	420	16,53	570	22,44	1016	40,00	Type 2
BA 100	315	12,40	515	20,28	1008	39,69	Type 3
BA 100 PCL/300	335	13,19	485	19,09	1016	40,00	Type 3



Information

Other models/options, contact us.

1.6.1.3 Dimensions BA 200 / BA 400

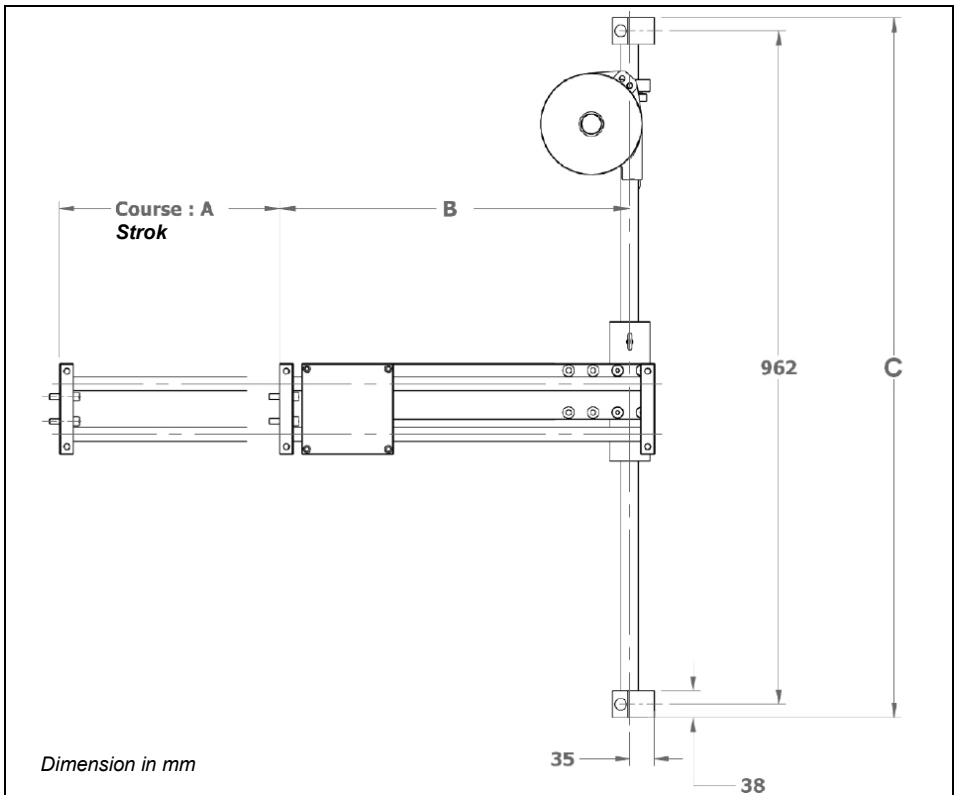

Designation	B min		B max		C (without post)	
	(mm)	(in)	(mm)	(in)	(mm)	(in)
BA 200	430	16,93	500	19,69	1000	39,37
BA 400	326	12,83	406	15,98	1000	39,37



Information

BA 200/400/1000 series arms are delivered without clamps or posts and they are not anodized (standard delivery).

1.6.2 Articulated torque reaction arm's specifications

1.6.2.1 Technical characteristics

** with additional balancer*

Designation	Max Torque		Ø Tools min-max		R maxi at 22,5°		Max Load	
	(N.m)	(lbf.in)	(mm)	(in)	(mm)	(in)	(kg)	(lbs)
BA 5 R	5	44,26	25-42	0,98-1,65	420	16,54	0,9	1,98
BA 12 R	12	106,21	27-50	1,06-1,97	450	17,72	1,2	2,64
BA 12 RPC					450	17,72	1,2	2,64
BA 12 R/600					600	23,62	1	2,20
BA 25 R	25	221,28	28-52	1,10-2,05	460	18,11	2,2	4,84
BA 25 RPC					460	18,11	2,2	4,84
BA 25 R/600					600	23,62	1,9	4,19
BA25 RPC/600					600	23,62	1,9	4,19
BA 25 R/800					800	31,49	1,5	3,30
BA 40 R	40	354,04	28-52	1,10-2,05	650	25,59	2,2 / 4*	4,84/8,8
BA 40 RPC					650	25,59	2,2	4,84
BA 40 R/800					800	31,49	2 / 3,5*	4,41/7,71
BA 40 RPC/800					800	31,49	2	4,41
BA 40 R/1000					1000	39,37	1,8 / 3*	3,96/6,61
BA 100 R	100	885,10	28-52	1,10-2,05	730	28,74	3/5*	6,61/11,02
BA 100 RPC					730	28,74	3,5	7,70
BA 100 R/900					900	35,43	3 / 5*	6,61/11,02
BA 100 RPC/900					900	35,43	3	6,61
BA 100 R/1100					1100	43,30	2,5/4*	5,51/8,8*
BA100RPC/1100					1100	43,30	2,5	5,51



Warning

Make sure to never use the tools beyond the torque values for which they are designed.



Warning

Never use the tools with effective loads at the end of the arm exceeding the manufacturer's recommendations.

1.6.2.2 Dimensions

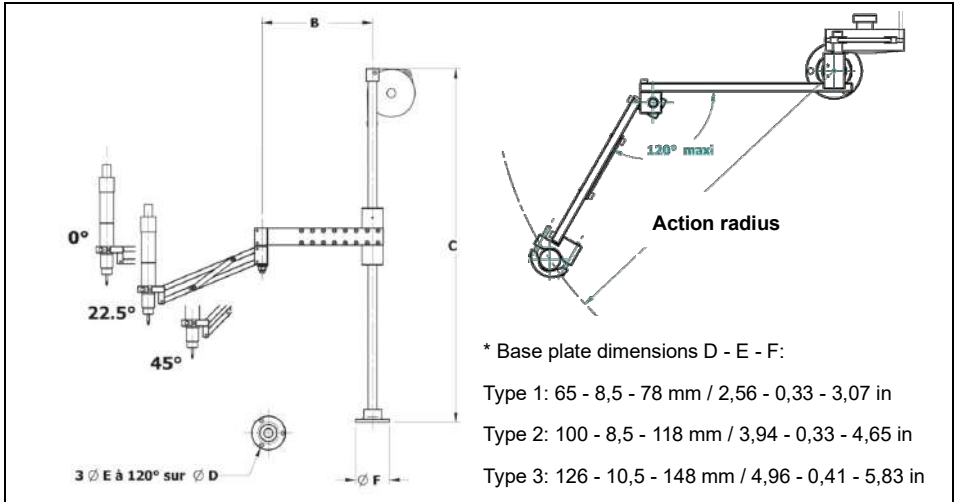

Designation	A 0°		A 22,5°		A 45°	
	(mm)	(in)	(mm)	(in)	(mm)	(in)
BA 5 R	259	10,20	243	9,57	192	7,56
BA12 R / BA 12 RPC	279	10,98	261	10,28	209	8,23
BA 12 R/600	332	13,07	310	12,20	247	9,72
BA 25 R / BA 25 RPC	296	11,65	278	10,94	227	8,94
BA 25 R/600 et RPC/600	358	14,09	336	13,23	271	10,67
BA 25 R/800	483	19,02	452	17,80	360	14,17
BA 40 R / BA 40 RPC	414	16,30	387,5	15,26	360	14,17
BA 40 R/800 et RPC/800	503	19,80	470	18,50	310,5	12,22
BA 40 R/1000	640	25,20	597	23,50	471	18,54
BA 100 R et BA 100 RPC	462	18,19	433	17,05	351	13,82
BA 100 R/900 et RPC/900	564	22,20	528	20,79	425	16,73
BA 100 R/1100 et RPC/1100	694	27,32	648	25,51	517	20,35

Designation	B min		B max		C		Base Plate*
	(mm)	(in)	(mm)	(in)	(mm)	(in)	
BA 5 R	132	5,20	212	8,35	705	27,76	Type 1
BA12 R	102	4,02	252	9,92	808	31,81	Type 1
BA 12 RPC	145	5,71	245	9,65	816	32,13	
BA 12 R/600	332	13,07	357	14,06	808	31,81	
BA 25 R	95	3,74	245	9,65	908	35,75	Type 1
BA 25 RPC	145	5,71	245	9,65	916	36,06	
BA 25 R/600	305	12,01	330	12,99	908	35,75	
BA25 RPC/600 *	330	12,99	330	12,99	916	36,06	
BA 25 R/800	417	16,42	442	17,40	908	35,75	
BA 40 R	150	5,91	350	13,78	1008	39,69	Type 2
BA 40 RPC	200	7,87	350	13,78	1016	40,00	
BA 40 R/800 *	415	16,34	415	16,34	1008	39,69	
BA 40 RPC/800	503	19,80	470	18,50	1016	40,00	
BA 40 R/1000 *	520	20,47	520	20,47	1008	39,69	
BA 100 R	205	8,07	405	15,94	1008	39,69	Type 3
BA 100 RPC	255	10,04	405	15,94	1016	40,00	
BA 100 R/900	470	18,50	520	20,47	1008	39,69	
BA 100 RPC/900 *	520	20,47	520	20,47	1016	40,00	
BA 100 R/1100	585	23,03	635	25,00	1008	39,69	
BA100RPC/1100 *	635	25,00	635	25,00	1016	40,00	

Information



Other models/options, contact us.

* Model not adjustable on B.

1.6.3 Pneumatic articulated torque reaction arm's specifications

1.6.3.1 Technical characteristics

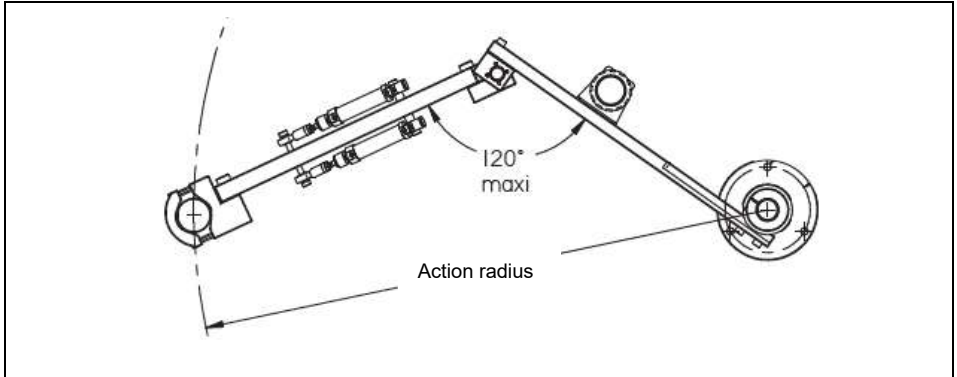

Designation	Max Torque		Tool Ø min-max		Stroke		Action radius		Max Load	
	(N.m)	(lbf.in)	(mm)	(in)	(mm)	(in)	(mm)	(in)	(kg)	(lbs)
BA10 G	10	88,51	27-50	1,06-1,97	170	6,69	470	18,50	1	2,20
BA10 G/600							600	23,62		
BA30 G	30	265,53	28-52	1,10-2,05	220	8,66	670	26,38	2	4,40
BA30 G/800							800	31,50		

1.6.3.2 Dimensions

* Base Plate dimensions G - E - F:

Type 1: 65 - 8,5 - 78 mm / 2,56 - 0,33 - 3,07 in

Type 2: 100 - 8,5 - 118 mm / 3,94 - 0,33 - 4,65 in

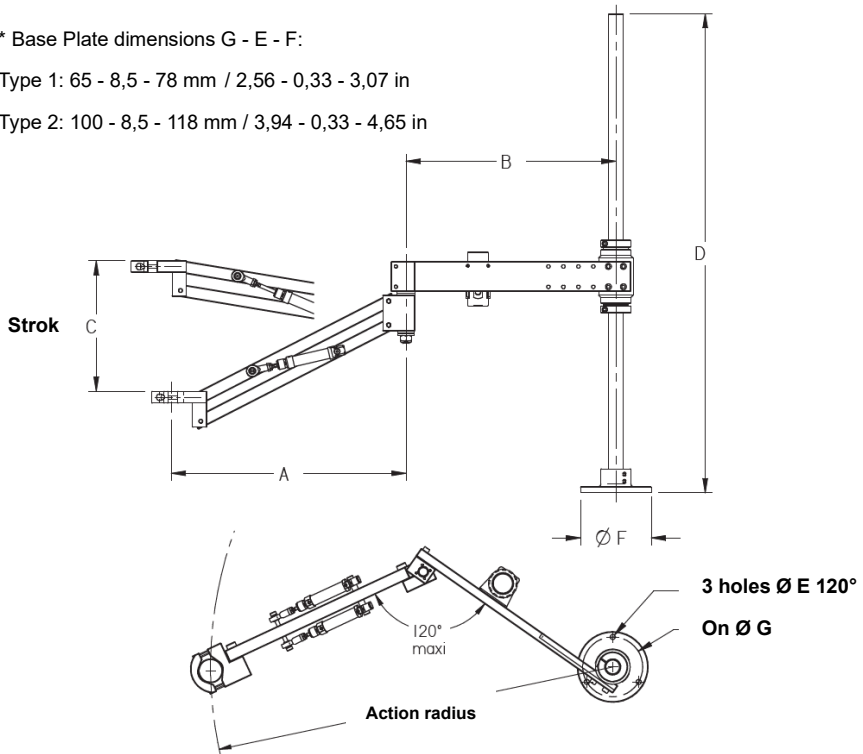

Designation	A low position		B min		B max		D		Base Plate*
	(mm)	(in)	(mm)	(in)	(mm)	(in)	(mm)	(in)	
BA10 G	260	10,24	202	7,95	252	9,92	600	23,62	Type 1
BA10 G/600			357	14,06	407	16,02			Type 1
BA30 G	391	15,39	250	9,84	350	13,78	800	31,50	Type 2
BA30 G/800			405	15,94	505	19,88			Type 2

1.6.4 Cartesian torque reaction arm specifications

1.6.4.1 Technical characteristics

Designation	Max Torque		Tool Ø min-max		Stroke		Max load	
	(N.m)	(lbf.in)	(mm)	(in)	(mm)	(in)	(kg)	(lbs)
BA 25 C	25	221,28	28 - 52	1,10 - 2,05	250	9,84	2,2	4,84
BA 100 C	100 / 50*	885,10 / 442,55			325	12,80	3	6,60
BA 200 C	200	1770,20	-		350	13,78	8	17,60

* Max torque 50 Nm (442,55 lbf.in) if installed on a lateral linear guide.



Information

BA...C series are delivered as standard without lateral linear guide. This option allows a translation of 420 / 820 / 1320 / 1820 mm (16,54 / 32,28 / 51,97 / 71,65 in) depending on the model chosen.



Warning

Make sure to never use the tools beyond the torque values for which they are designed.



Warning

Never use the tools with effective loads at the end of the arm exceeding the manufacturer's recommendations.

1.6.4.2 Dimensions

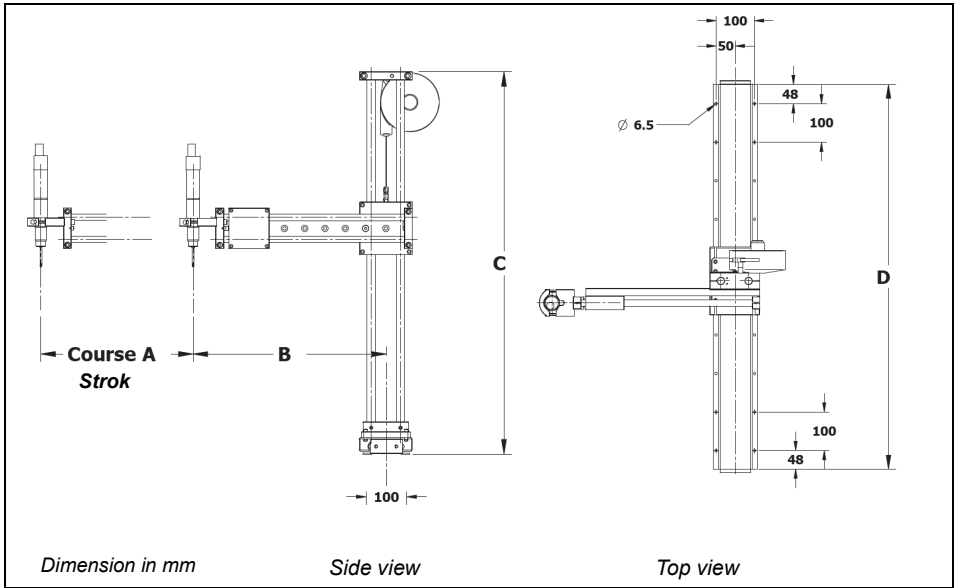

Designation	B mini		B maxi		C		D (acc. to model)	
	(mm)	(in)	(mm)	(in)	(mm)	(in)	(mm)	(in)
BA 25 C	207	8,15	327	12,87	737	29,02	600 / 1000 /	23,62 39,37
BA 100 C	259	10,20	483	19,02	940	37,01	1500 / 2000	59,06 78,74
BA 200 C	320	12,60	450	17,72	1050	41,34	-	



Information

Other model/options, contact us.

2. STARTING UP

2.1 Workstation description

Torque reaction arm is fixed on a stable workstation or on the ground and equipped with a tightening tool.

2.2 Unpacking

Remove the arm from its packaging.

Information



Before use, check over the entire package and look for any signs of damage. Do not use the product if you notice that it is damaged.

Warning



Danger of suffocation!
Be careful not to leave empty packages lying around.

Dispose of the packaging in accordance with applicable national legislation.

2.3 Configuration

The arm is customizable thanks to a wide choice of options and accessories.

2.4 Installation

Warning

Protective gloves are recommended while installing torque reaction arms to avoid pinching and cutting hazards.

2.4.1 Main shaft foot installation

Position the main shaft foot on a perfectly horizontal work surface or on the ground. Make sure that arm travel is possible without interference, or possible harm to operators, and that the work area is fully accessible.

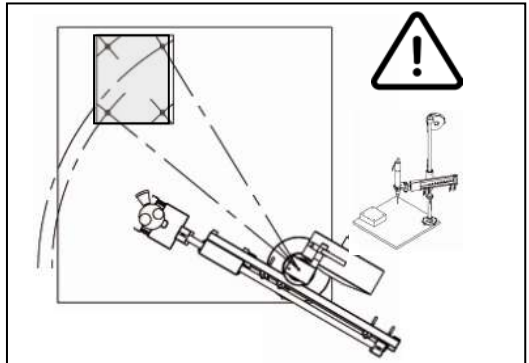

Firmly fix the base with 3 screws (not supplied).

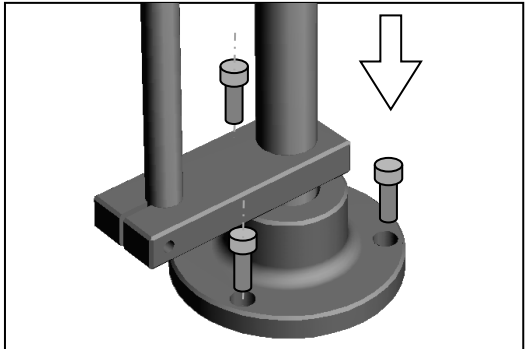

Warning

The global stroke of the arm must be taken into consideration before workstation setup.

2.4.2 Shift adjustment B min. / B max.

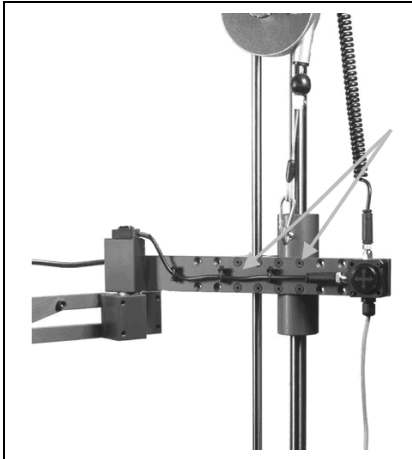

The primary arm plate installs on the main shaft. The position is adjustable between limits B min. and B max.

Be careful to avoid damage to encoder cables during adjustment.

2.4.3 Tool installation

Mount the tool with the clamp as follows:

- Loosen the two clamp screws with a suitable handtool. Position the tool in the clamp so that the clamp will hold the tool in the correct location. Moderately tighten the two screws until the screwing tool is firmly held.



Warning

An excessive clamping can affect the function of the tool mounted on the arm.



Warning

Insufficient clamping will not guarantee cancellation of the torque reaction effect.

2.4.4 Balancer installation

Install the balancer by firmly tightening the screw.

Use the spacers provided to properly align the balancer (20 Nm + loctite 243).

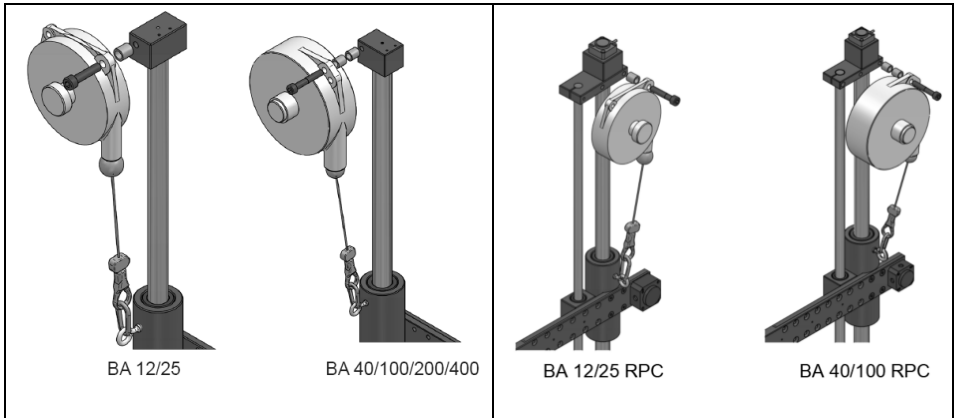

Information
 Please refer to the instruction manual of your balancer model.

2.4.5 Encoder check (Series : BA...PCL, BA...RPC, BA...GPC)

Connect the encoder cables to the junction box, then connect the DB9 cable to the DPC Touch V2 (DOGA position control system).

Check that the coverage of the tightening area is within a range of 300 to 3700 points on the Y shaft encoder (rotation):

- Refer to the encoder positioning data provided by the DPC Touch V2 under the «Operation Mode» menu.
- If this is not the case:
 - Loosen the set screws (1). Rotate the shaft (2) until it is within this range.
 - Then retighten the set screws.

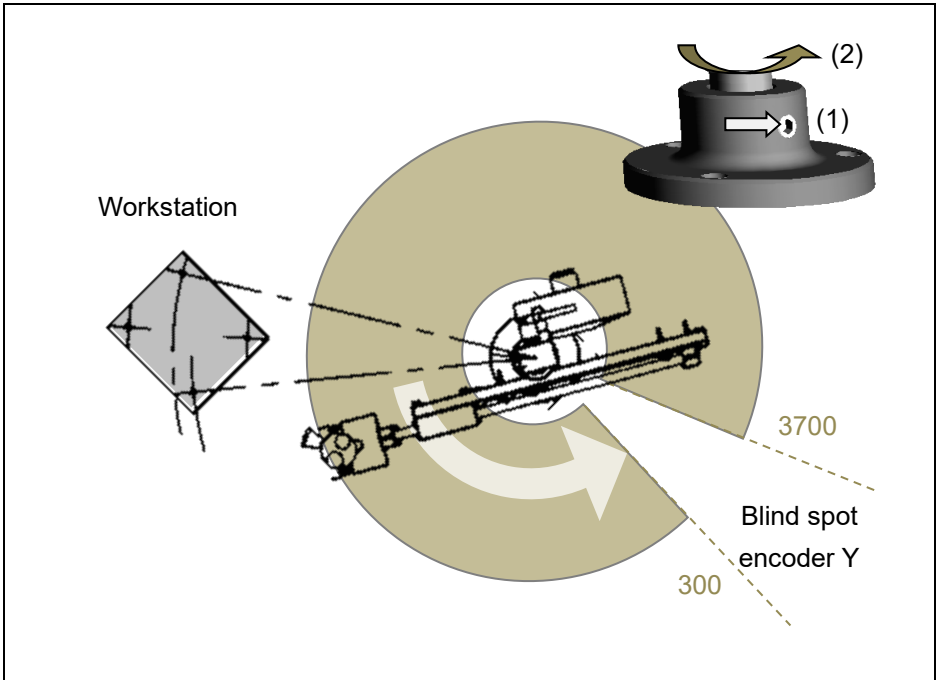

2.4.6 Mounting instructions BA...PCL

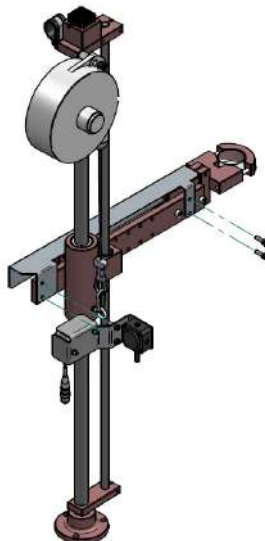

2.4.7 Air pressure check (serie BA...G, BA...GPC)

Supply compressed air connection Ø ext. 6 mm (0,24 In).

The minimal pressure is 6,3 bars (91 PSI).

3. SETTINGS

3.1 Balancer setting

It is the effective load at the end of the arm which gives the balancer tension. The load is well balanced when the operator can handle the tool easily.

- Decrease the tension by turning the adjuster in the clockwise direction.
- Increase the tension by turning the adjuster in the counterclockwise direction.



Warning

The rope run must be adjusted appropriately using the rubber ball.



Important

Refer to the indications on the body of the balancer.

3.2 Inclination setting (BA...R series)

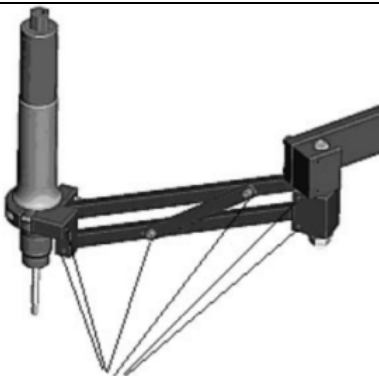

Adjust the inclination of the forearm (0°, 22,5° or 45°) making sure that the angle of the hinge does not exceed 120°.

4. USE



Warning

Protective gloves are recommended while installing torque reaction arms to avoid pinching and cutting hazards.

4.1 Standard use

The arm is fully mechanical and is manually oriented according to the operator's needs.

4.2 Positioning control use

The arm is fully mechanical and is manually oriented according to the operator's needs.

The position encoders allow for position control of the arm.



Information

Refer to the instruction manual of the DPC Touch V2

5. MAINTENANCE



Information

The torque reaction arms are designed for a duty cycle of approx. 300,000 fastening without maintenance.

5.1 Servicing

The motion of the sliding axis can deteriorate and harden over time due to dust or dirt. Periodic cleaning should be carried out following the instructions below:

- Disassemble the chrome slides and bearing sleeves. Use compressed air to clean the ball bushings.
- Wipe down the main shaft and the chrome slides with a dry cloth.
- Reassemble the arm while checking the alignment of the chrome slides and correctly tightening of the clamp.



Information (position control series: PC)

The encoders do not require any maintenance.

5.2 Troubleshooting

As part of the production, the proper functioning of the arm has been checked several times. However, if an arm malfunctions, refer to the following troubleshooting list.

Malfunction	Action to take
The arm doesn't reach the requested position	Check the stroke and the distance compared to the fixing point of the base plate. Dismantle and remount the arm closer to the required position.
Encoder signal is not received (BA...PCL, BA...RPC, BA...GPC series)	Check the connection of the encoders to the junction box as well as the DPC Touch V2. Check if the encoder has been damaged (if so, replace it).
The tool does not maintain vertical position (descends)	Check that the weight of the tool is less than the capacity of the arm. Refer to paragraph 3.1 for the balancer setting.
The tool does not maintain vertical position (rises)	Refer to paragraph 3.1 for the balancer setting.

If you cannot solve an issue after reviewing this manual, please contact the DOGA service department.



My client area on www.doga.fr

Go to your client area on www.doga.fr, click "Your contacts", then select your specific **After-sales department contact** depending on the device type.

5.3 Spare parts

For any spare parts order, contact your DOGA technical sales representative. Indicate your torque arm reference as well as the part to be replaced (refer paragraph 1.4).



My client area on www.doga.fr

Go to your client area on www.doga.fr, click “Your contacts”, then select your specific **After-sales department contact** depending on the device type.

5.4 Phone support

5.4.1 For any questions about using the device



My client area on www.doga.fr

Go to your client area on www.doga.fr, click “Your contacts”, then select your specific **After-sales department contact** depending on the device type.

5.4.2 For any questions about repairs



My client area on www.doga.fr

Go to your client area on www.doga.fr, click “Your contacts”, then select your specific **After-sales department contact** depending on the device type.

If our technician can remotely determine the origin of the fault, he will tell you what to do in order for you to repair it by yourself as much as possible.

5.5 After-sales returns

All material must be returned with an after-sales service return form, that you must complete and attach to your package.

Repair, maintenance or adjustments can only be started after the receipt of this form.



Information

Following this procedure allows you to quickly take charge of your request and reduces the troubleshooting costs.

DOGA reserve the right to apply a trade-in discount and to invoice, if applicable, the costs of repairing and packaging.

5.5.1 Download the after-sales return form

You can download the return form by following one of these links:

<http://service.doga.fr/syst/dogatech.nsf/liste/00184>

<https://www.doga.fr/en/our-services/industrial-maintenance>



Information

You can use your own after-sales service return form as long as it contains all the information necessary to take care of your equipment.

5.5.2 Send your equipment

The returned package must be postage paid to the following addresses depending your transport mode:

Postal packages	Carrier packages
DOGA - Service SAV 8, avenue Gutenberg - CS 50510 78317 Maurepas Cedex FRANCE	DOGA - Service SAV 11, rue Lavoisier 78310 MAUREPAS FRANCE

5.6 On-site repair

Even though it seems convenient, on-site repair is seldom the best solution for transportable equipment. The conditions in which the technician will work are not as ideal as our workshops and technician travel expenses are costly.

If you require an on-site service, please contact the after-sales department.



My client area on www.doga.fr

Go to your client area on www.doga.fr, click “Your contacts”, then select your specific **after-sales department contact** depending on the device type.

Our services will organize the service.

5.7 Warranty

DOGA guarantees all our products against any defect in parts or fabrication for a period of **12 months**.

To benefit from the parts and labor warranty, the following conditions must be respected:

- The torque reaction arm must have been used in a professional manner and in accordance with the limits of use described in the instruction manual.
- The torque reaction arm must not have suffered any damage from storage, maintenance or improper handling.
- The torque reaction arm must not have been modified or repaired by unqualified persons.

6. SAFETY

6.1 General provisions



The instruction manual must be carefully stored in a known place and easily accessible to the potential users of the product.



Caution

Read this manual and have each operator read it carefully before installing, using or repairing.

Make absolutely sure that the operator has fully understood the rules of use and the meaning of any symbols affixed to the product.

Most accidents could be avoided by following the instruction manual.

These rules have been drafted with reference to the European directives and their various amendments as well as standard rules product.

In each case, respect and comply the national safety standards.

Do not remove or damage the labels and annotations affixed to the product, especially those required by law.

6.2 Residual risks

6.2.1 Pinching or cutting risks

Moving components can cause injuries. Protective gloves are recommended while installing torque reaction arms to avoid pinching and cutting risks.

6.2.2. Injury risk

A person hitting the arm with a part of his body (unprotected by safety equipments) exposes himself to the risk of injury.

6.3 Contra-indications

Do not immerse.

Do not expose to splashing liquids.

Do not expose to dusty atmospheres.

Do not oil the axes.

Do not use near to a heat source.

7. STANDARDS

7.1 Manufacturer details

Manufacturer : DOGA

Address : ZA Pariwest

8 avenue Gutenberg CS 50510

78317 MAUREPAS CEDEX - FRANCE

7.2 Markings

BA / BA...PCL / BA...TWIN / BA...R / BA...RPC / BA...G / BA...GPC / BA...C	Designation of equipment
Torque (N)	Max admissible torque
Capacity (kg)	Max admissible load
 8 avenue Gutenberg - CS 50510 78317 Maurepas Cedex - FRANCE	Name and address of the equipment manufacturer
CE	Equipment designed and manufactured in accordance with the requirements of European directives 2006/42/CE.

7.3 Transport and storage

Information



Your equipment can be damaged if you store it or transport it improperly. Observe the transport and storage information for your equipment.

7.3.1 Transport

Use a suitable container to transport the equipment to protect it from damage.

7.3.2 Storage

Respect the following guidelines before storing:

- Disconnect the encoder cable (PC only).
- Clean the arm according to the maintenance chapter.
- Store it in a suitable container to protect it from dust and direct sunlight.
- Store it in a dry place at an ambient temperature, below 40°C.



7.4 Recycling and end of service life

At the end of service life, torque reaction arms must be sent to suitable recycling programs for ferrous (steel and iron) and non-ferrous (other metal such as aluminium).

8. ANNEXES

8.1 EC declaration of conformity

Download the CE declaration of conformity by following the link or by scanning the QR code corresponding to your product:

Models	Web link	QR code
<p>BA BA...R SLIDER SLIDER BA SLIDER BA...R Mounting rails BAPER Easy Push</p>	<p>http://service.doga.fr/syst/dogatech.nsf/liste/00106</p>	
<p>BA...PCL BA...RPC SLIDER BA...PCL SLIDER BA...RPC</p>	<p>http://service.doga.fr/syst/dogatech.nsf/liste/00172</p>	

Download
the ultimate version of this manual
via this link below or via QR code:

<http://service.doga.fr/syst/dogatech.nsf/liste/60351>

